

# ISOTHERM

Control unit for panel heating systems

Constant temperature maintenance

## Technical Data Sheet



## Description and application

The **ISOTHERM** is a control unit designed for use for constant control of the supply temperature in panel heating systems or in panel heating systems in combined with a high-temperature heating circuit.



### Control unit ISOTHERM

Ready-to-mount, compact control unit to control supply temperature in radiant panel heating systems up to 15 kW heat demand. Set-point value for supply temperature can be adjusted via thermostatic injection valve. Pre-wired pump and temperature limiter 30 - 90 °C. Can be mounted either on the left or right side of the heating circuit manifold. Suitable for all Watts 1" M heating circuit manifolds.

Type	Part no.	Setting range	Pump	Weight
ISOTHERM	10084162	30-50 °C	Wilo Para SCU/6	4.09 kg
ISOTHERM	10087337	30-50 °C	Lowara Eco2/6	4,20 kg
ISOTHERM	10084351	45-60 °C	Wilo Para SCU/6	4.09 kg
ISOTHERM	10084637	45-60 °C	Grundfos UPM3A/7	4.30 kg
ISOTHERM	10087338	45-60 °C	Lowara Eco2/6	4,20 kg

## Technical characteristics and materials

Technical characteristics	
Operating ambient temperature:	0 - 40 °C
Operating medium temperature:	0 - 90 °C
Max. operating pressure:	6 bar
Setting range of supply temperature <sup>1)</sup> :	30 - 50 °C   45 - 60 °C
Factory pre-setting of target supply temperature:	44 °C   55 °C
Factory pre-setting of the temperature limiter:	55 °C   65 °C
Heating demand:	up to 15 kW, $\Delta T = 10K$
Operating voltage:	230 V - 50 Hz
Primary (heat generator):	1" M, flat sealing
Secondary (heat distribution):	1" union nut, flat sealing

Materials	
Fittings:	Brass CW617N
Pipe parts:	Brass CW508L
Plastics:	Impact resistant and temperature resistant
Seals:	AFM 34/2
O-Rings:	EPDM

1) Two versions of Isotherm with 2 setting ranges depending on the version of the mixing valve.

## Structure

- 1 Thermostatic mixing valve
  - 2 Setting hand wheel of the mixing valve
  - 3 Circulation pump 130 mm
  - 4 Temperature limiter
  - 5 Bypass
  - 6 Thermometer 0 - 60 °C
- A Primary supply (1" male thread)
  - B Primary return (1" male thread)
  - C Surface heating/cooling supply (1" union nut)
  - D Surface heating/cooling return (1" union nut)

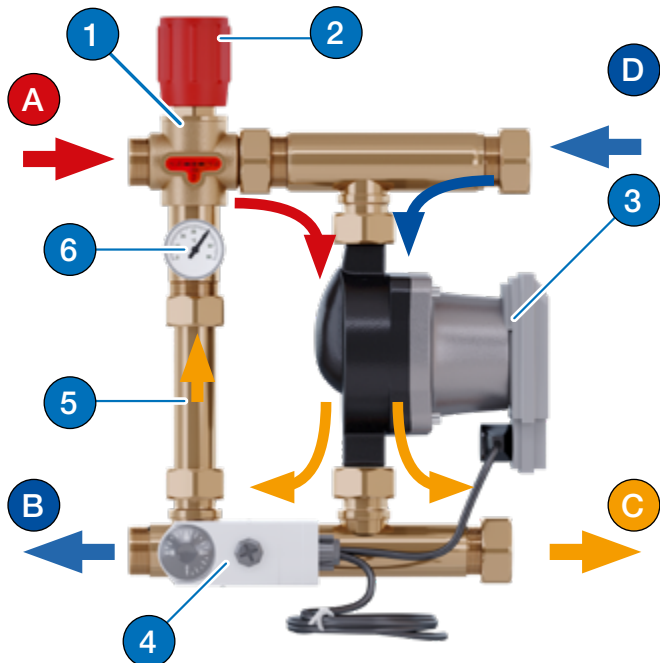

## Operation

The mixing valve (1) is designed as a proportional controller and operates without the need for a power supply. The supply temperature adjusted on the setting handwheel (2) is continuously controlled by a thermostat element. This sensor is constantly flowed around by a partial volume flow with the current flow temperature via the bypass (5). The current supply temperature is displayed on the thermometer (6). Deviations from the target value result in an immediate change in valve stroke and, accordingly, a change in the volume of the hot water injected from the primary supply (A).

The injected water volume from primary circle (A) is mixed with the return water from the manifold (D) at the inlet to the circulation pump (3) and, in this way, keeps the supply temperature constant within a narrow temperature range.

The mixed medium is distributed via the circulation pump (3) to the supply of the surface heating / heating circuit manifold (C) and from there to the connected heating circuits as well as being routed as a pilot flow via the bypass (5).

In the event of malfunction, the temperature limiter (4) attached to the supply line switches off the circulation pump (3) to prevent overheating of the surface heating system.

## Example of application

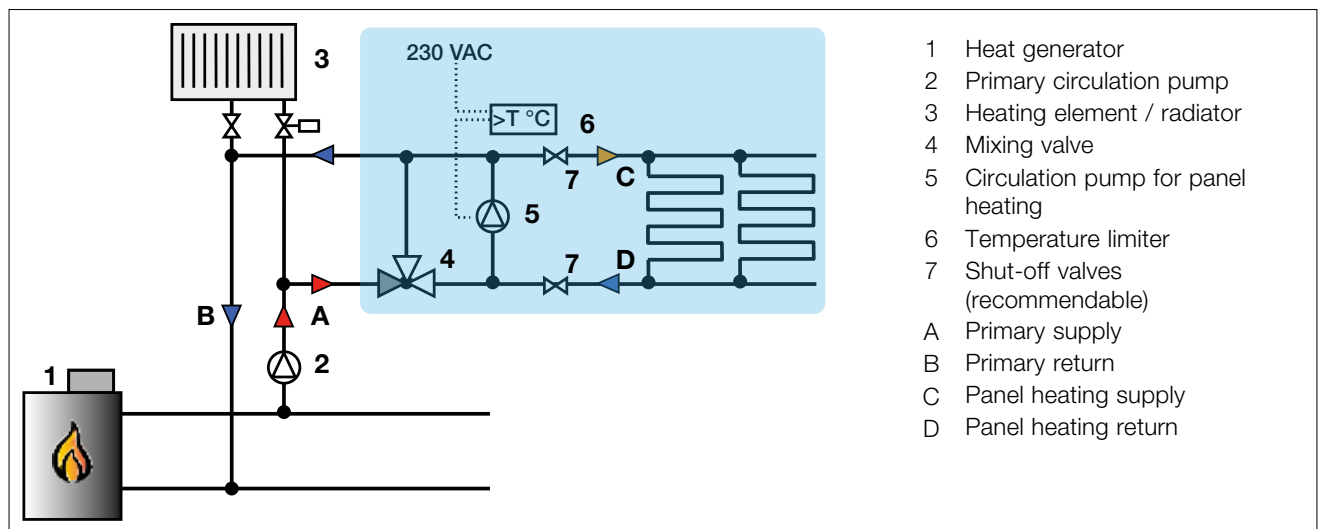

## Mounting

The control unit **ISOTHERM** is supplied ready for mounting to the left of the heating circuit manifold with side connection 1" male thread and connection centre's of 210 mm. If you want to mount it to the right of the heating circuit manifold, all you have to do is reposition the thermometer.

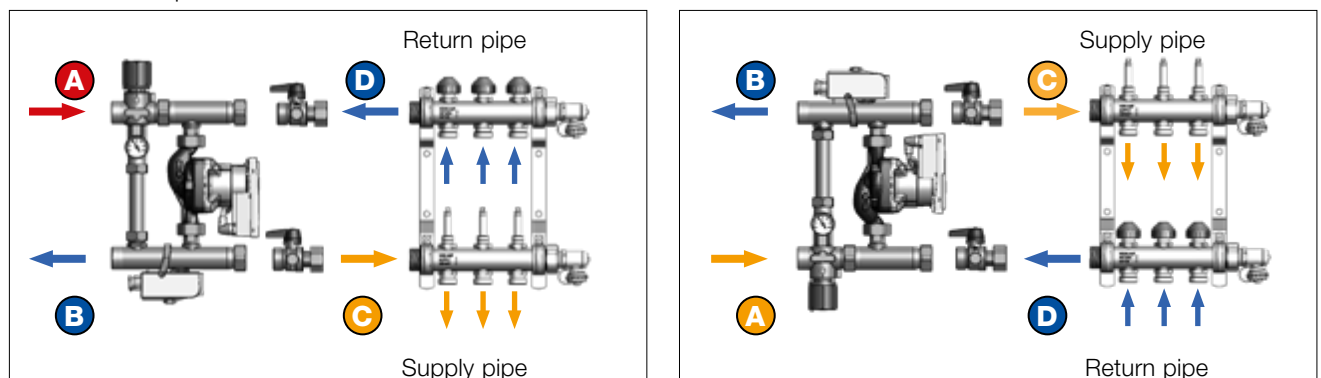

## Setting of the target supply temperature

↓ To reduce the target temperature  
Turn the setting wheel clockwise.

1 Click = -1 °C.

The pilot pin moves out in the process

↔ Factory setting Set point 44 / 55 °C,  
depending on version.

The pilot pin is flush.

↑ To increase the target temperature  
Turn the setting wheel counterclockwise.

1 Click = +1 °C.

The pilot pin "sinks".

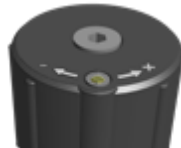

## Pressure loss diagram

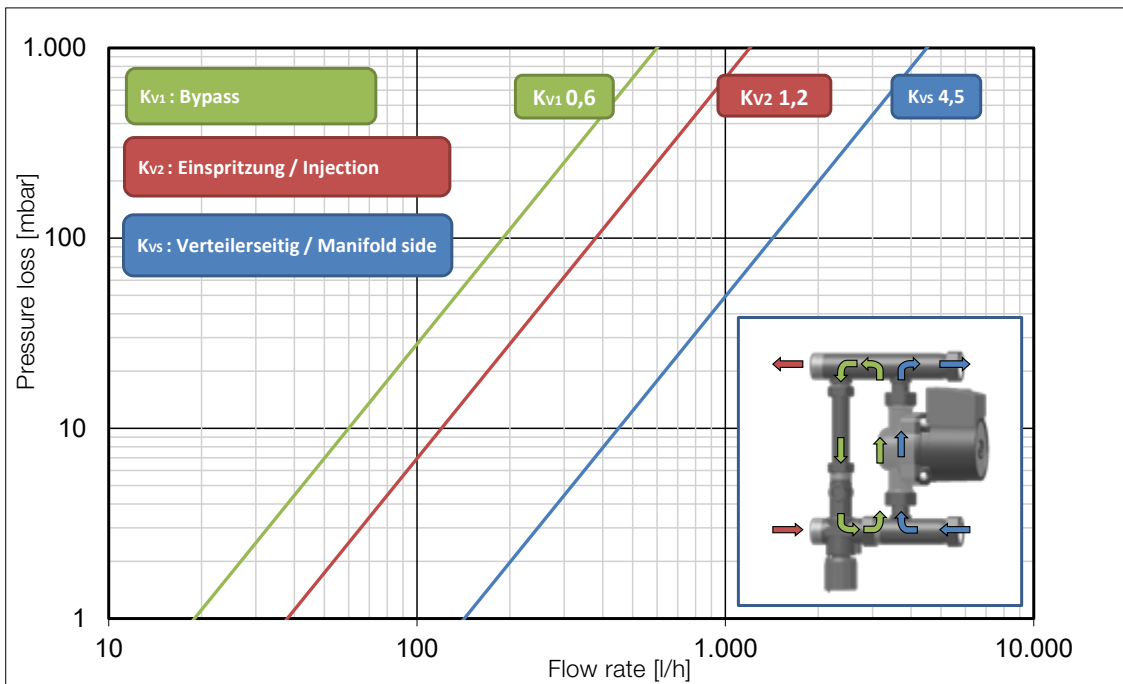

## Overall dimensions [mm]

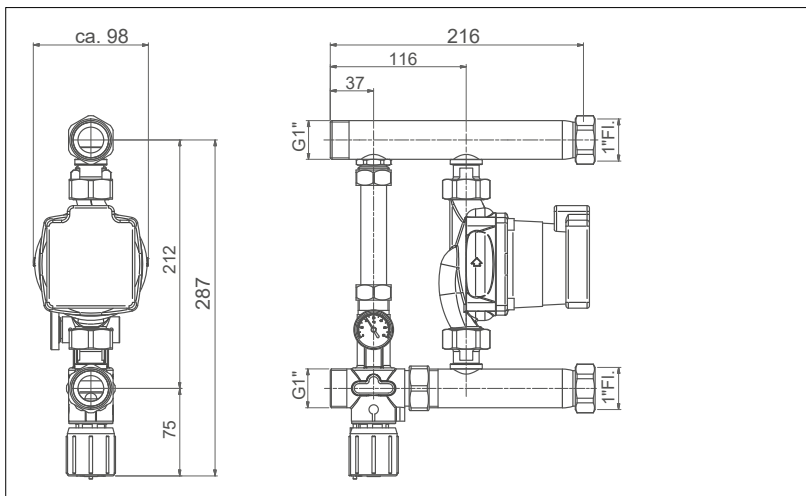

## Specification text

### WATTS control unit Type: ISOTHERM

Ready-to-mount, compact control unit to control supply temperature in radiant panel heating systems up to 15 kW heat demand. Set-point value for supply temperature can be adjusted via thermostatic injection valve. Temperature range 30 - 50 °C or 45 - 60 °C. Pre-wired pump and temperature limiter. Designed for installation on heating circuit manifolds with 1" Male thread and center distance 210 mm. Can be mounted either on the left or right side of the heating circuit manifold. Suitable for all Watts 1" M heating circuit manifolds.

The descriptions and photographs contained in this product specification sheet are supplied by way of information only and are not binding. Watts Industries reserves the right to carry out any technical and design improvements to its products without prior notice. Warranty: All sales and contracts for sale are expressly conditioned on the buyer's assent to Watts terms and conditions found on its website at [www.watts.eu/gtc/](http://www.watts.eu/gtc/). Watts hereby objects to any term, different from or additional to Watts terms, contained in any buyer communication in any form, unless agreed to in a writing signed by an officer of Watts.

**WATTS**<sup>®</sup>

Watts Industries Deutschland GmbH

Godramsteiner Hauptstr. 167 • 76829 Landau • Deutschland

Telefon: +49 6341 9656-0 • Fax: +49 6341 9656-560

E-Mail: [WIDE@wattswater.com](mailto:WIDE@wattswater.com) • [www.watts.eu/de](http://www.watts.eu/de)